

INWARD
Opening window

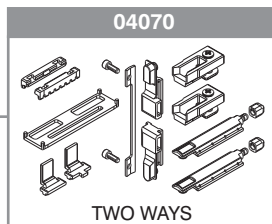

TILT AND TURN
Opening window

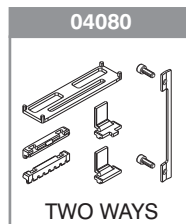
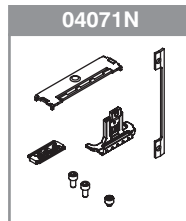

OUTWARD
Opening window

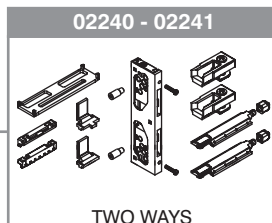
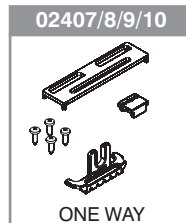
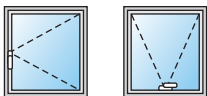

GIESSE UNICA APEX CREMONE

The quick and easy solution for fastening shutters and outward openings



Giesse widens the range of Unica cremones with the new **Apex** mechanism, an article designed for creating the fastener of an Outward Opening.

The Apex cremone does not require the conventional internal mechanism, since the connection pins can fit directly on the telescopic sliders.

The **Giesse patented system** for fixing the cremone on the profile ensures quick, secure and lasting application. Additional self-threading screws are not needed.

The most suitable connection pin is chosen according to the sash profile geometry. In particular, the pins compatible with the cremone body and 02259000 are given in the table "Connection pins".

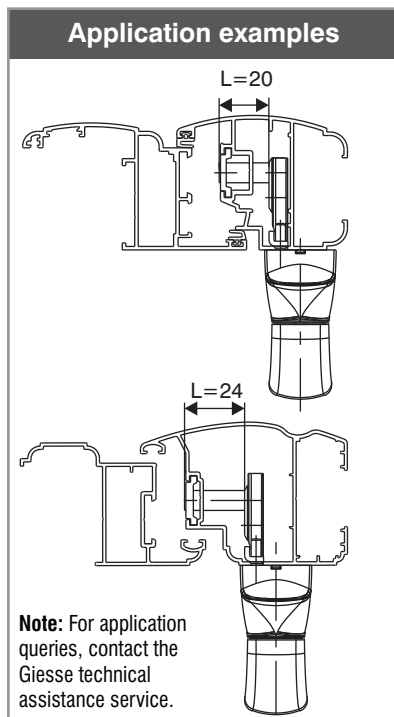
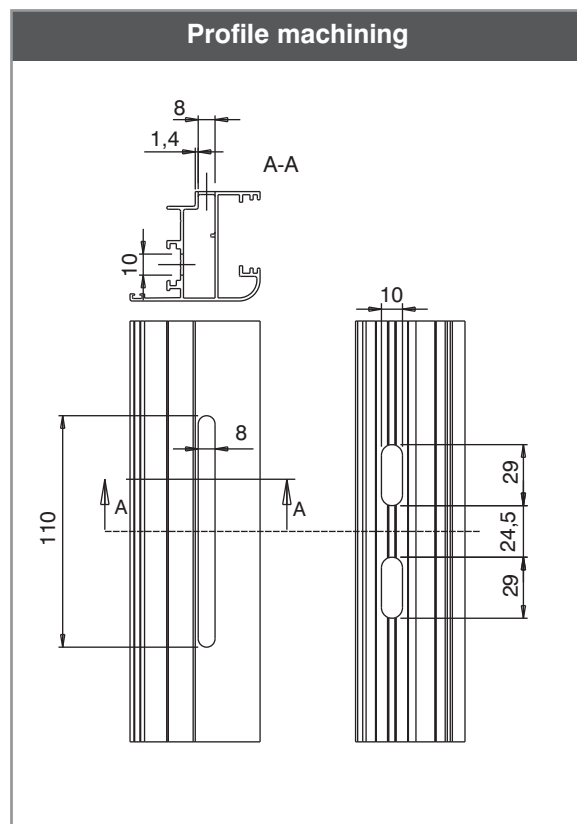

Cremone installation sequence



1) Fit the fixing plate on the lower part of the cremone using a 3 mm hex wrench.

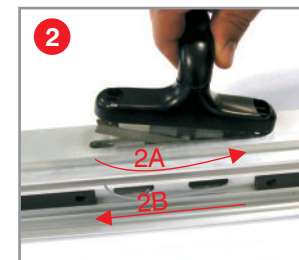

2) Insertion in profile
2A) Insert the cremone upward and then
2B) Bring the system downward.

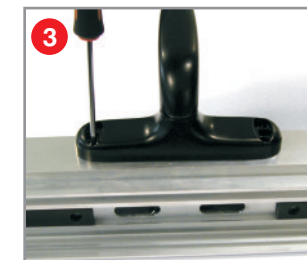

3) Partially tighten the first screw so that the plate, inside the tubular section, is brought near the profile.



4) Tighten down the second screw and then the first screw.

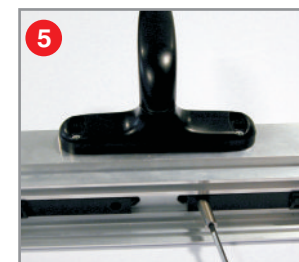

5) Fit the appropriate connection pins.

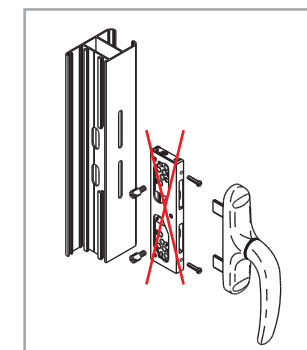

Connection pins	
Article	L
02251K	10 mm
02252K	13 mm
02253K	16 mm
02254K	24 mm
02255K	20 mm

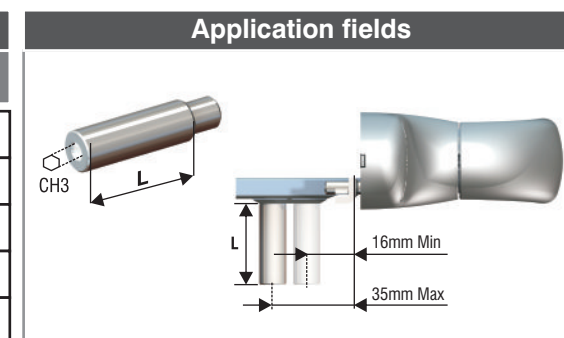

Note: New connection pins in Silver Plus GS finish for high corrosion resistance.

The 3 mm hexagon impression facilitates screwing the pins on the slider.