

GS1000-ML

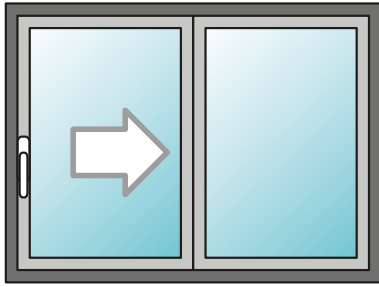

Single pulleys

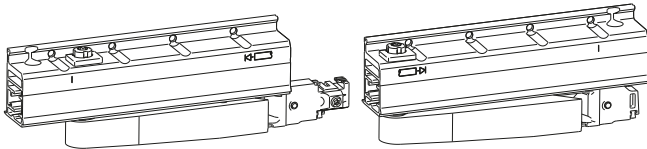

Hardware set without reinforcements

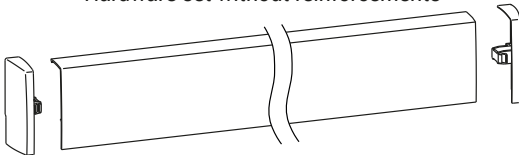

Adjustable strikers

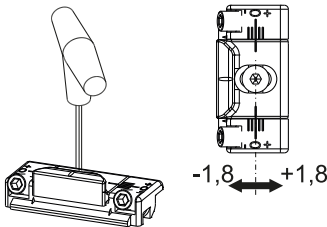

Futura corner drive

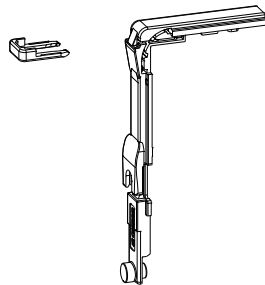

GS1000-ML TILT AND SLIDE

Functions

Tilt and slide system with manual operation using standard cremone or window handle.

For applications with sashes weighing up to 100 kg.
Available for Euro groove and R40 profiles.

Technical Features

GS1000-ML is ideal for windowsill applications. Enables making sashes of reduced dimensions and weights up to 100 kg.

Uses single pulleys without flat side plugs and reinforcements.

GS1000-ML can be made in these configurations:

- for Euro groove with cremone/window handle
 - for R40 with cremone/window handle
- depending on the specific hardware set that you choose.

GS1000-ML uses the Giesse Futura tilt-and-turn fastening mechanism with the Giesse polyamide rod.

The hardware components are pre-assembled and are attached to the profile by interlocking or with contrast grubscrews, without any specific machining.

The Euro groove hardware set uses adjustable strikers (± 1.8 mm), while the R40 hardware set has adjustable pawls (± 1.2 mm), to optimize the perimeter pressure of the sash.

It is possible to add up to four additional locking points, depending on the size of the sash, to improve the air/water seal.

On both versions it is possible to add burglar-proof devices along the perimeter of the sash (except for R40 configurations).

Automatic catch

GS1000-ML features the automatic catch system (*) installed at the bottom of the sash.

This device facilitates closing the sash that, when put in the closed position, automatically locks in the tilt position.

Turning the cremone from 180° (sliding position) to 90° (tilt position) and putting the sash into the closed position engages the sash in the tilt position.

To close the sash simply move it against the frame and turn the cremone down a further 90° to 0° (closed).

(*) not available in the configuration for R40

GS1000 ML Additional locking points

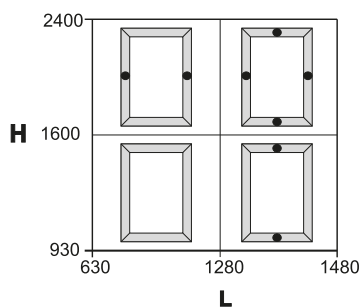

Operating scheme

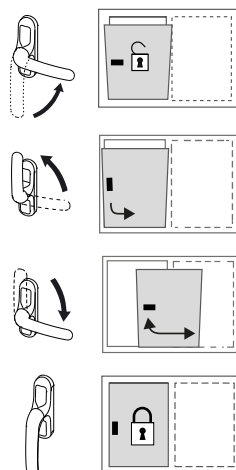

"LOGICA" opening mechanism

GS1000-ML uses the LOGICA opening system (**) whereby operating the cremone produces first tilt opening and then slide opening. Taking the cremone to 90° operates tilt opening and turning it to 180° operates slide opening.

To engage the automatic catch, the cremone must be turned back to 90° and the sash closed against the frame.

(**) excluding the version for R40 in which there is first sliding opening then tilt-and-turn opening

Incorrect movement safety device plates

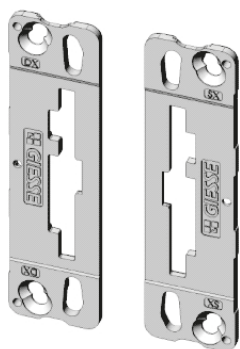

Incorrect movement safety device

The "incorrect movement safety device" prevents incorrect cremone operation when opening and closing the sash, avoiding malfunctioning or damage to the casement.

In the cremone configuration, the incorrect movement safety feature is obtained by replacing the plate supplied with the standard cremone with one of the two plates (left/right) included in the cremone hardware set.

In this way the cremone can turn from 180° to 90° to allow automatic engagement, but it cannot turn from 90° to 0° if the sash is not tilted close, so as to prevent accidental impact of the strikers and pawls.

In the window handle configuration, the mechanism itself (available in right- and left-hand versions) is fitted with an incorrect movement safety device that prevents operating the cremone from 90° to 0° with the sash sliding open.

Adjustment of the side reinforcements

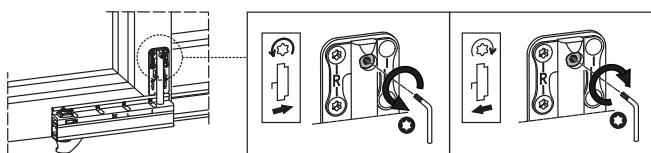

Correct positioning of the sash

To improve the overall alignment of the sash with the frame, there are several adjustments:

- height adjustment of the sash via the pulleys (-2/+4 mm)
- side adjustment via the command striker
- adjustment of the side reinforcements to improve the sash out and return phase
- adjustment of the sash-frame parallelism

Sash-frame parallelism

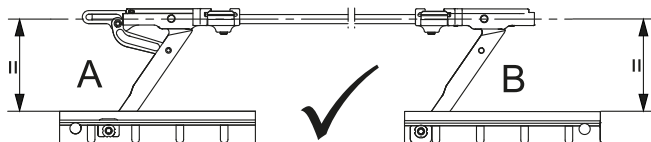

Height adjustment

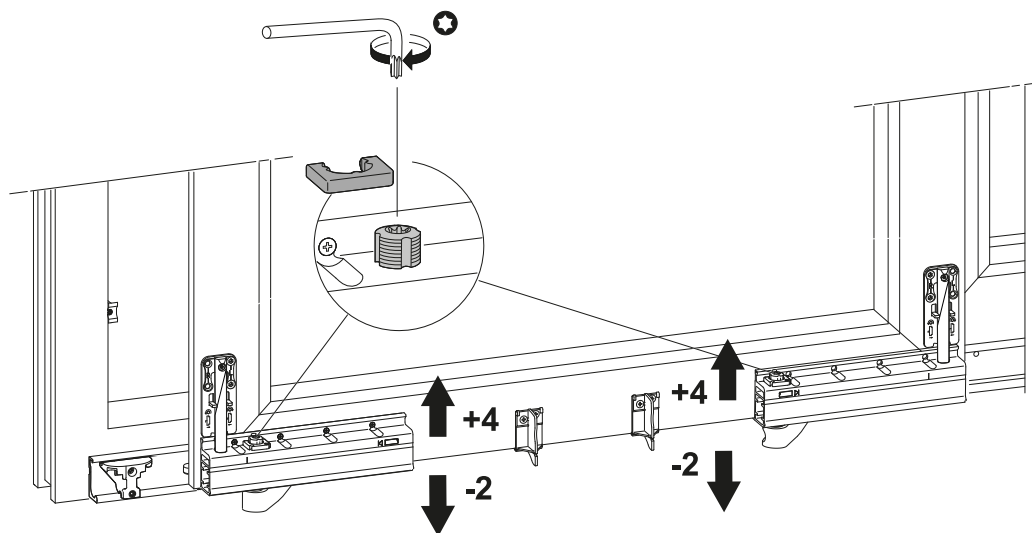

GS1000-ML TILT AND SLIDE

Application section

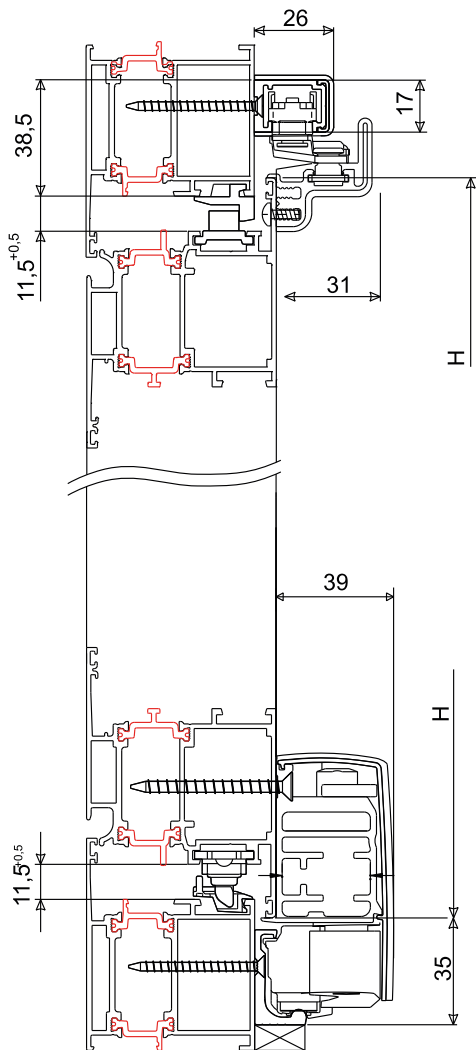
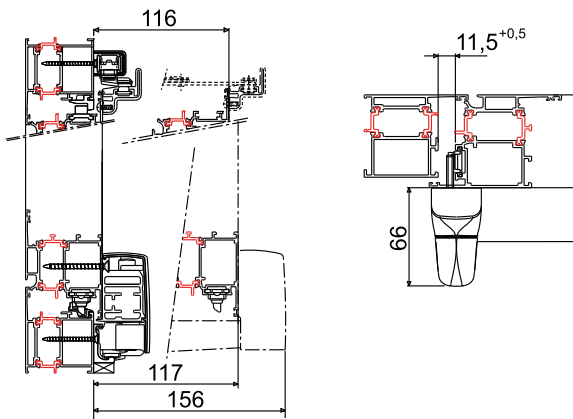

GS1000-ML range of use

Applications on aluminium doors and windows

Sash weight (kg) = max 100 kg

Sash width (W) = 630 to 1480 mm

Sash height (H) = 930 to 2400 mm

Minimum required dimensions

Bottom rail = 35 mm

Top rail = 38.5 mm

Bottom rail depth = 17 mm

Step ≥ 7 mm

Sash depth D:

≤ 87 mm check not required

> 87 mm do only after technical verification (return trajectory and sash centre of gravity)

Important note

The H/L ratio ≤ 2.5 given in the scheme is binding and must not be exceeded.

In all cases, refer to the profile manufacturer's instructions and comply with the requirements.

Take the due precautions to avoid straining the mechanism in specific sites such as hotels, schools, kindergartens, etc.

Range of use

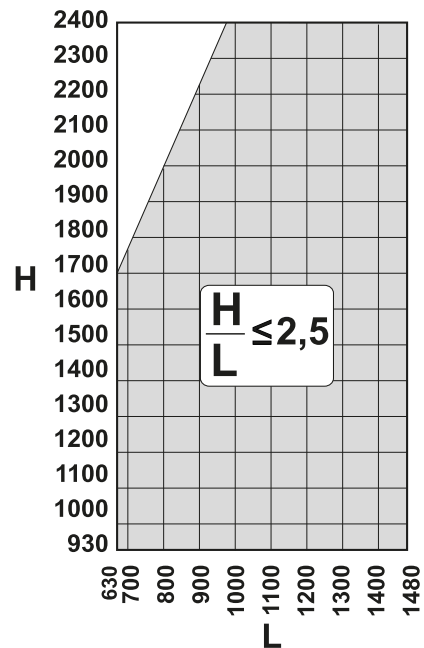

G = step
D = sash depth

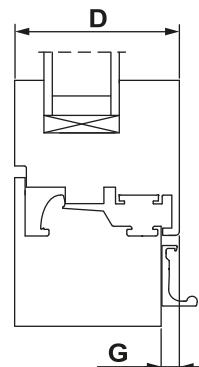

A typical GS1000-ML configuration consists of:

- single pulley set
- hardware set available in the Euro groove version for cremones, in the Euro groove version for window handles and in the R40 version for cremones and window handles
- stay arm
- profile set
- accessories set without side reinforcements
- cremone/window handle
- mobile control (in the case of an opening secondary sash)

Scheme for GS1000-ML Euro groove profile
with cremone/window handle

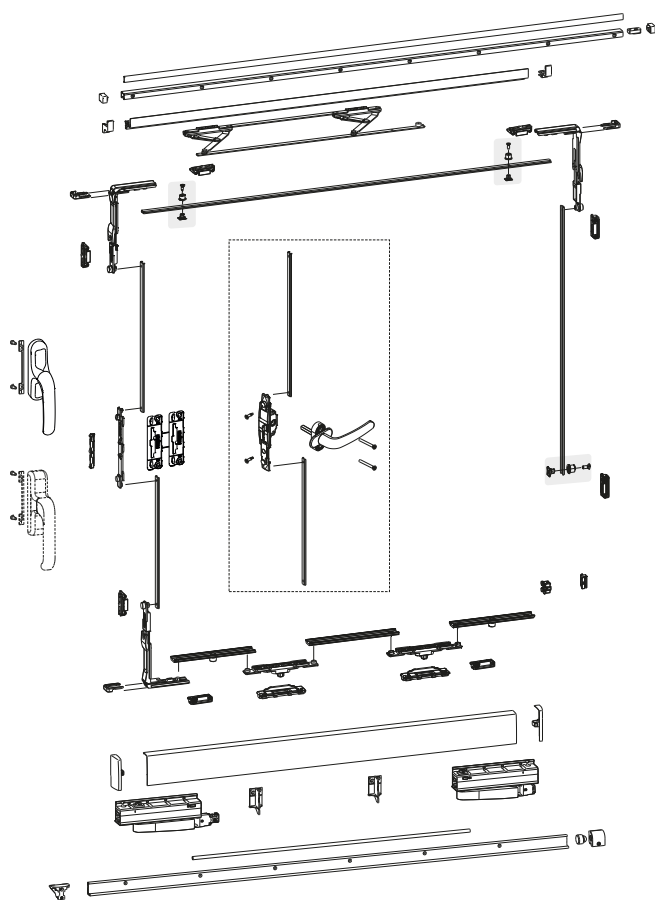

Scheme for GS1000-ML R40 profile
with cremone/window handle

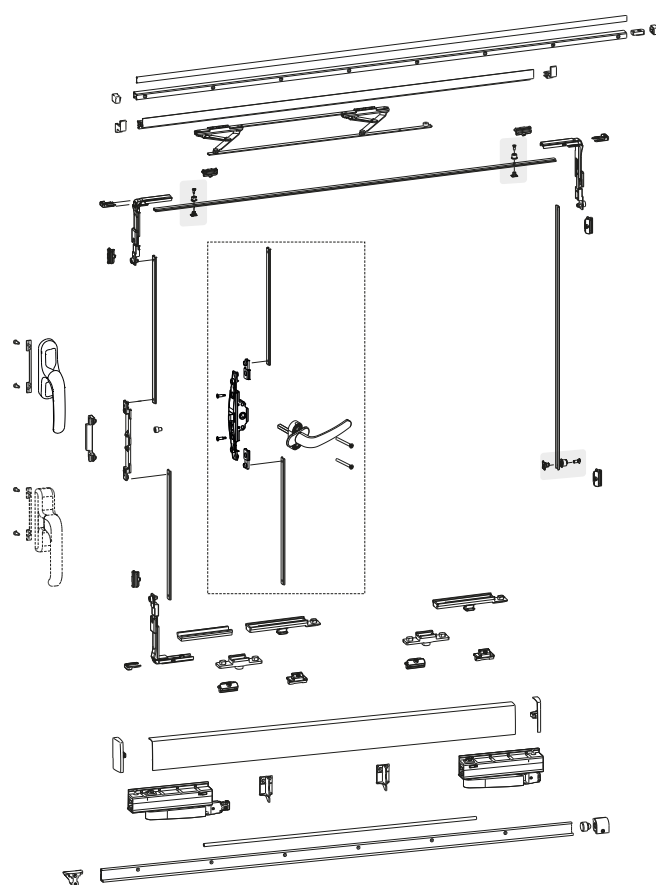

OPENING SCHEMES

A1 - Two sashes
Left-sliding sash and fixed/opening secondary sash

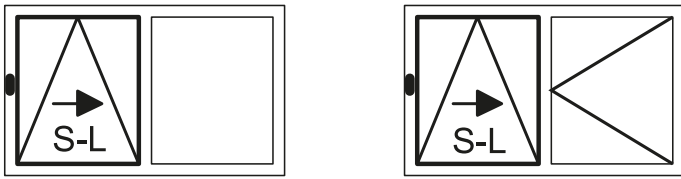

A2 - Two sashes
Right-sliding sash and fixed/opening secondary sash

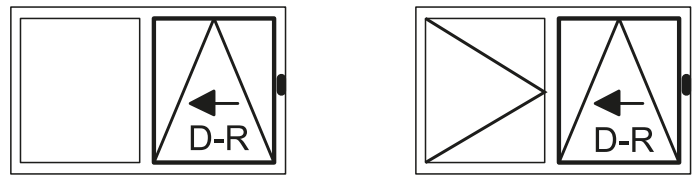

G1 - Three sashes
Left-sliding centre sash and fixed/opening secondary sashes

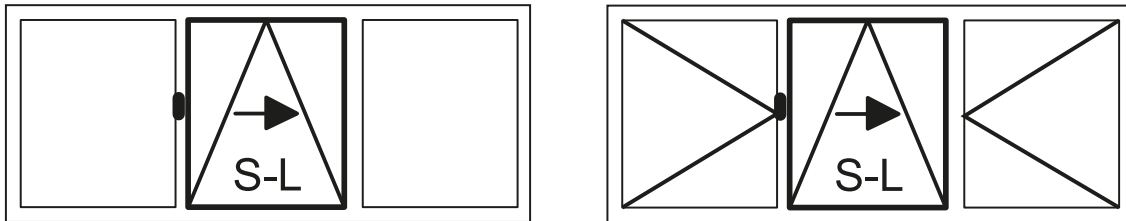

G2 - Three sashes
Right-sliding centre sash and fixed/opening secondary sashes

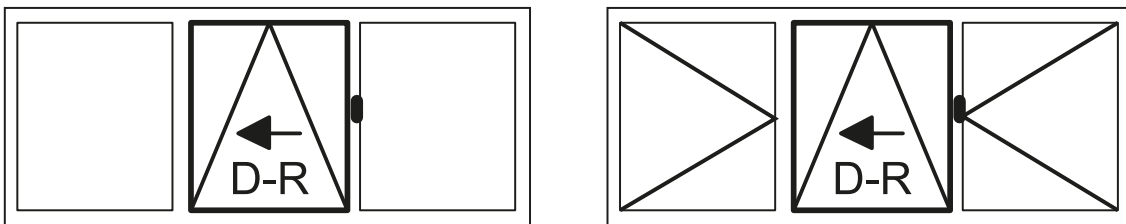

K - Three sashes
Fixed centre sash and sliding side sashes

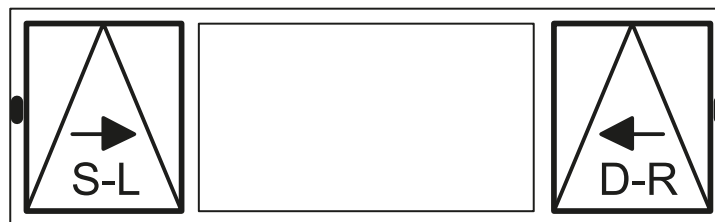

C - Four sashes
Sliding centre sashes and fixed secondary sashes (with/without central upright)

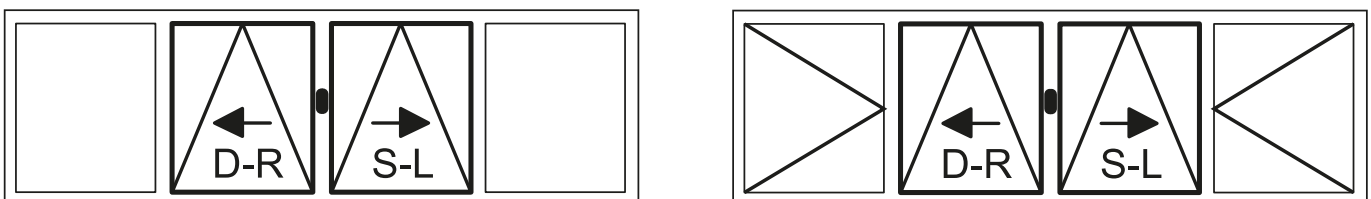

SINGLE PULLEYS

Functions

Single pulleys for GS1000 tilt and slide system.

Technical features

Single pulleys to be used for making windows with the following tilt and slide versions:

- GS1000-ML
- GS1000-HL
- GS1000-HD 100
- GS1000-HD 160

The set of single pulleys consists of a primary pulley, which controls sash return and a secondary pulley, available in right-hand and left-hand versions. The opening of the arm of the pulleys allows the sash to come out from the frame by 117 mm.

Applicable on profiles with a step greater than or equal to 7 mm.

Both pulleys are designed for use with side reinforcements that improve the seal of the profile (sold separately in the hardware set).

Using the pulleys it is possible to adjust the height of the sash (-2/+4 mm) and the parallelism between the sash and frame.

The machining on the profile for installing pulleys can be done with a specific drilling template.

Fixing to the profile is done with self-threading screws.

The pulleys are supplied with 2 supports for the bottom guard and the screws and bolts for fixing the pulleys and the set of rails.

Materials

Body and opening levers of aluminium

Wheel support of zamak

Polyamide wheels

Bottom guard supports of polyamide

Screws and pins of stainless steel

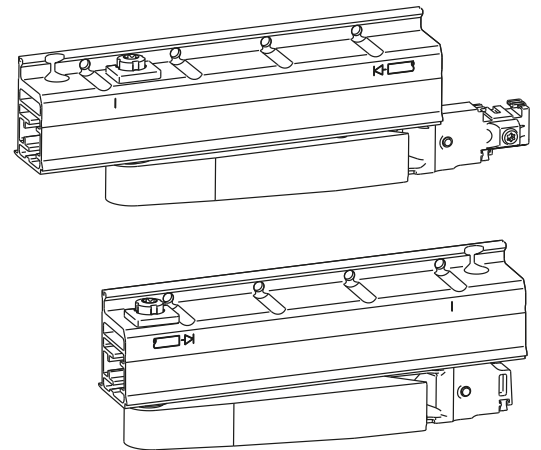

Single pulleys

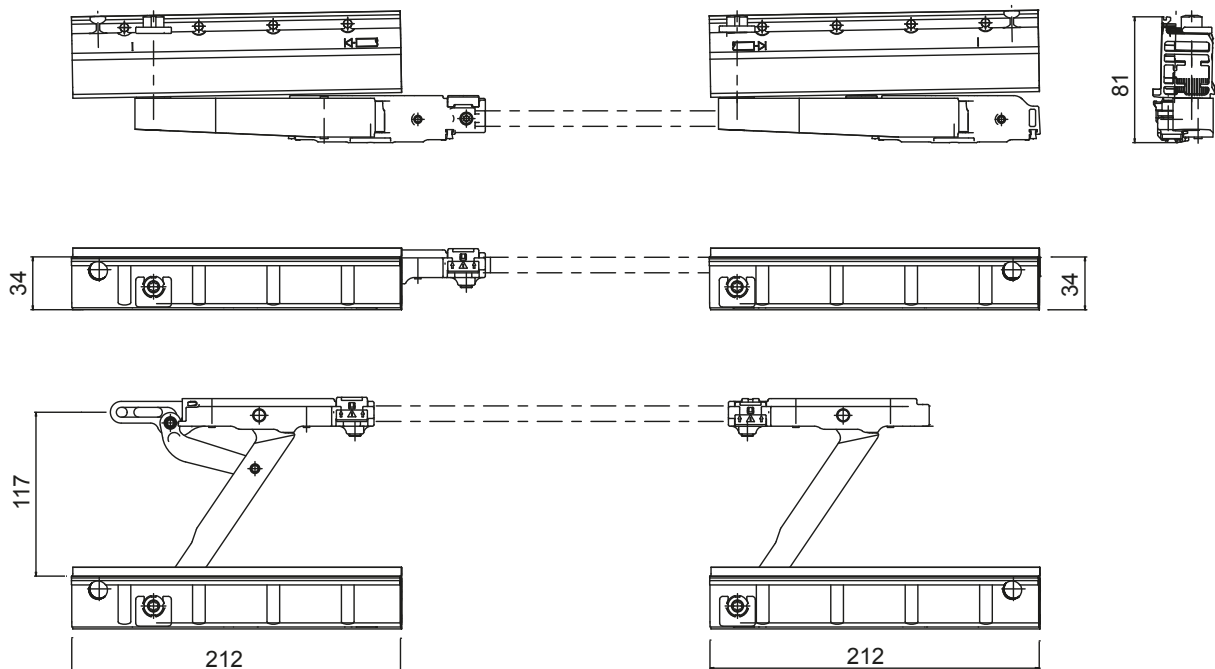

GS1000-ML TILT AND SLIDE

Height adjustment

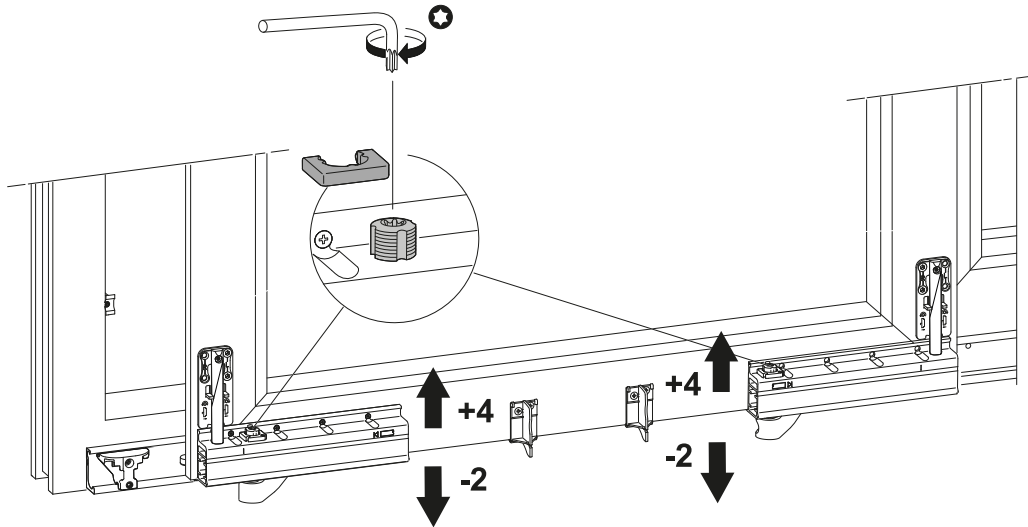

Sash-frame parallelism

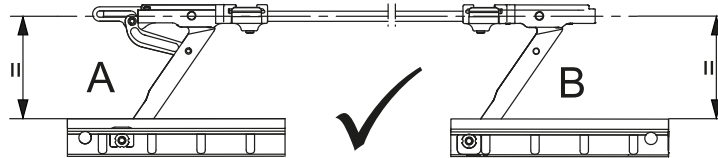

Item code	Description	Range [mm]	PROFILE CROSS - SECTION	GS1000-ML	GS1000-HL	GS1000-HD 100	GS1000-HD 160	GS1000-HD 200	Base Raw	Anodised Elox	Painted	Trend/Gold Brass	Pieces per pack
09776	SET OF RH SINGLE PULLEYS	-	-	X	X	X	X	-	X				1
09777	SET OF LH SINGLE PULLEYS	-	-	X	X	X	X	-	X				1

GS1000-ML AND GS1000-HL HARDWARE

Functions

Complete fastener system for making GS1000 tilt and slide type windows with manual control.

Available in versions for Euro groove for cremone and window handle and the version for R40.

Technical features

The fastening system uses the Futura tilt-and-turn fastening mechanism with a polyamide rod and LOGICA opening (*) with which operating the cremone produces first tilt opening, then slide opening.

The Euro groove hardware set uses fixed pawls and adjustable strikers (± 1.8 mm) with which you can optimize the perimeter pressure of the sash.

The R40 hardware set instead has fixed strikers and adjustable pawls (± 1.2 mm).

The hardware components are pre-assembled and are attached to the profile with contrast grubscrews, without any specific machining.

It is possible to add up to four additional locking points, depending on the size of the sash.

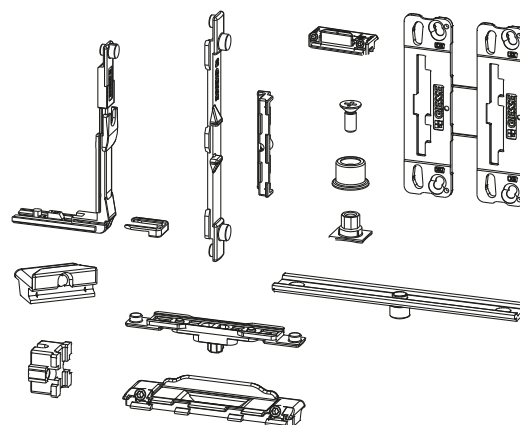

The hardware set consists of:

- no. 3 corner drives to transmit the motion between the uprights and cross-beams, to be secured to the profile with interlocking clips
- no. 1 cremone drive rod + no.1 incorrect movement safety striker (not included in the window handle hardware set)
- no. 8 locking points (pawls + strikers)
- no. 2 spring latches + strikers for the automatic locking system (not available in the version for R40)
- no. 2 connection rods with fastening mechanism pawl
- no. 1 lift-proof system (block + striker)
- no. 2 incorrect movement safety plates for cremones (1 right + 1 left) to replace the one supplied with the standard cremone
- no. 1 sticker for correct system operation

(*) excluding the configuration for R40

Materials

Drives, drive rod, strikers and pawls of zamak

Automatic catch strikers of zamak

Brass spring latches

Lift-proof striker + block of zamak

Polyamide connection rods

Polyamide incorrect movement safety device plates

Stainless steel mounting grubscrews

GS1000-ML TILT AND SLIDE

GS1000ML-HL hardware set

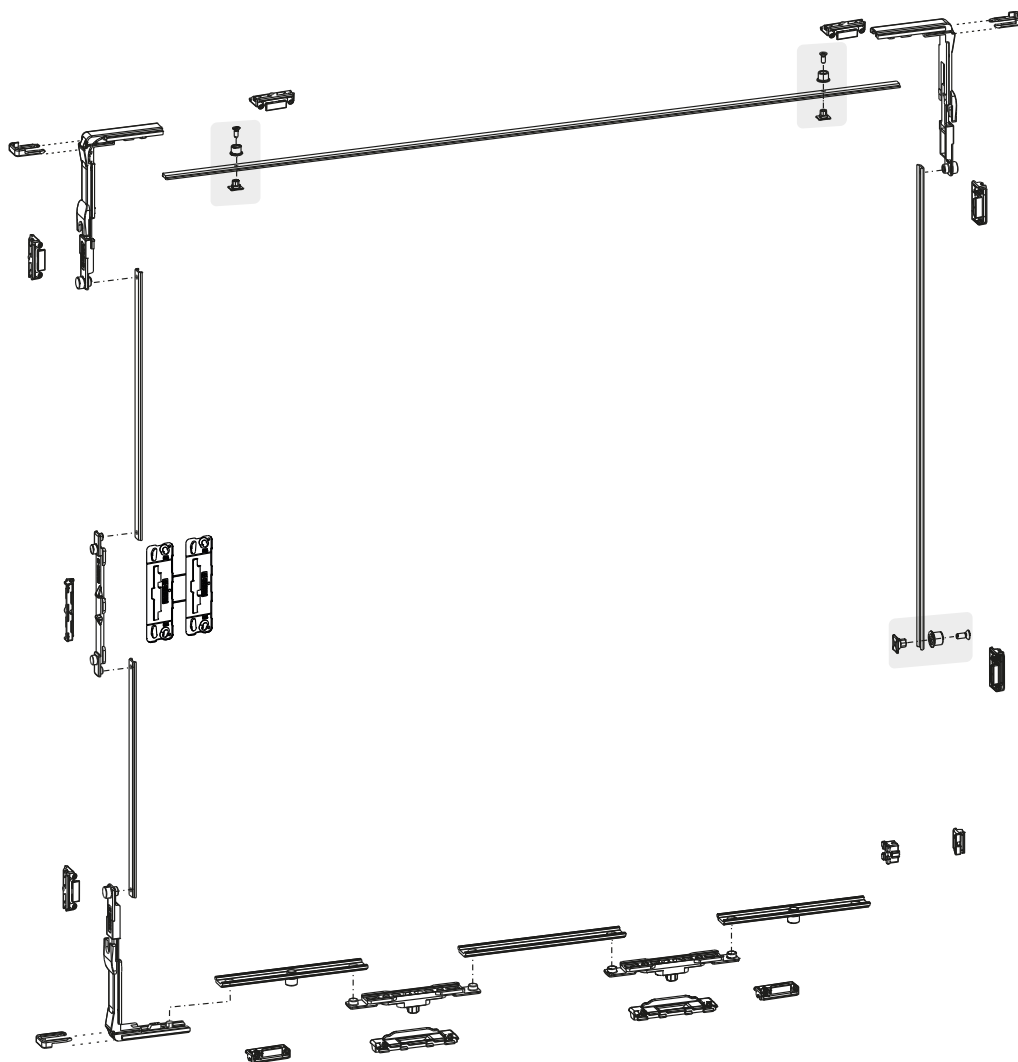

Item code	Description	Range [mm]	PROFILE CROSS - SECTION	GS1000-ML	GS1000-HL	GS1000-HD 100	GS1000-HD 160	GS1000-HD 200	Base Raw	Anodised Elox	Painted	Trend/Gold Brass	Pieces per pack
09780	GS1000-ML/HL HARDWARE SET	-	C001-C002-C003-C005	X	X	-	-	-	X				1
09783	GS1000-ML/HL WINDOW HANDLE HARDWARE SET	-	C001	X	X	-	-	-	X				1
09758	GS1000 R40 HARDWARE SET	-	C007	X	X	-	-	-	X				1

GS1000-ML/GS1000-HL ARMS

Functions

Stay arms for GS1000-ML and GS1000-HL tilt-and-slide system.

Technical features

The arms allow tilt-and-turn opening of the sash in conjunction with the fastening mechanisms.

They are available in three sizes to choose from according to the width of the sliding sash:

- for sashes of width 630-980 mm
- for sashes of width 981-1280 mm
- for sashes of width 1281-1680 mm

Materials

Steel arms

Sliders of nylon

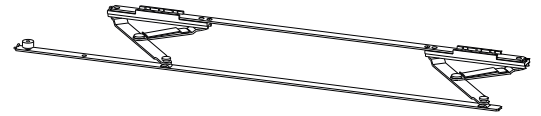

Item code	Description	Range [mm]	PROFILE CROSS - SECTION	GS1000-ML	GS1000-HL	GS1000-HD 100	GS1000-HD 160	GS1000-HD 200	Base Raw	Anodised Elox	Painted	Trend/Gold Brass	Pieces per pack
09723	630-930 WIDTH STAY ARM	630÷930	-	X	X	X	-	-	X				1
09724	931-1280 WIDTH STAY ARM	931÷1280	-	X	X	X	-	-	X				1
09725	1281-1680 WIDTH STAY ARM	1281÷1680	-	X	X	X	-	-	X				1

GS1000-ML TILT AND SLIDE

PROFILES SET

Functions

Profiles with the function of supporting and guiding in the phase of operating the sliding sash and with the function of a stylish cover for the GS1000 tilt and slide system.

Technical features

Each set of profiles consists of:

- top guards and track
- bottom guards and track
- screw protection plug
- pulley connection rod

The profiles set is available in various sizes, depending on the width of the sash to be constructed.

The bottom rail always has an anodised, silver or black finish.

The fixing of the profiles is by means of self-threading screws (supplied with the set of pulleys).

There are specific templates for the installation of the various profiles.

Materials

Rails and covers made of extruded aluminium

PVC screw cover rod (*)

Steel connection rod

(*) Available in the basic finishes of white, black and grey, combined with the various profile set finishes.

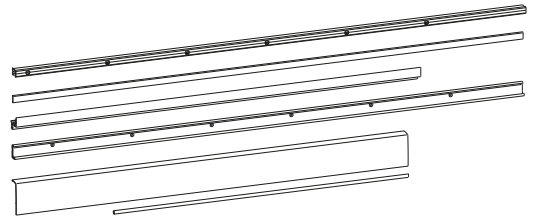

Application section

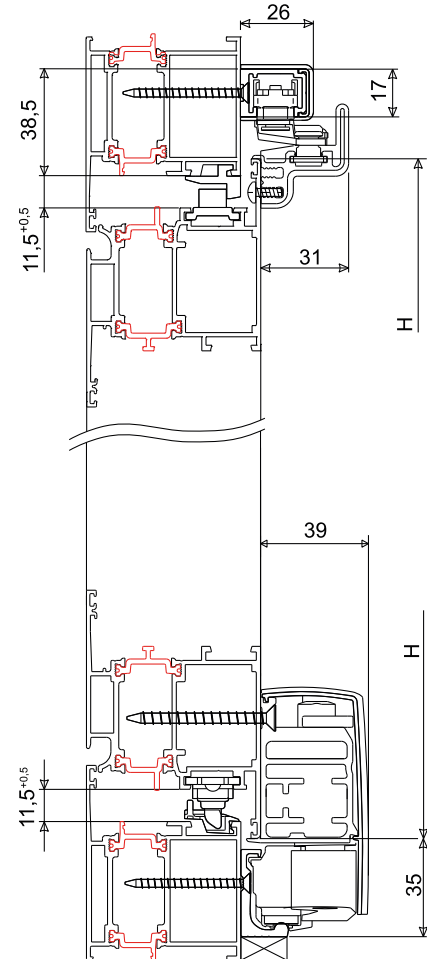

Item code	Description	Range [mm]	PROFILE CROSS - SECTION	GS1000-ML	GS1000-HL	GS1000-HD 100	GS1000-HD 160	GS1000-HD 200	Base Raw	Anodised Elox	Painted	Trend/Gold Brass	Pieces per pack
09761	630-880 PROFILES SET	630÷880	-	X	X	X	X	-	X	X	X		1
09762	881-1080 PROFILES SET	881÷1080	-	X	X	X	X	-	X	X	X		1
09763	1081-1280 PROFILES SET	1081÷1280	-	X	X	X	X	X	X	X	X		1
09764	1281-1480 PROFILES SET	1281÷1480	-	X	X	X	X	X	X	X	X		1
09768	TOP RAIL L=6000 mm	-	-	X	X	X	X	X	X	X	X		1
09769	BOTTOM RAIL L=6000 mm	-	-	X	X	X	X	X	X	X			1
09770	TOP GUARD L=6000 mm	-	-	X	X	X	X	X	X	X	X		1
09771	BOTTOM GUARD L=6000 mm	-	-	X	X	X	X	X	X	X	X		1
09772	PVC SCREW COVER L=6000 mm	-	-	X	X	X	X	X	X				1
09773	PULLEY CONNECTION ROD L=4000 mm	-	-	X	X	X	X	X	X				1

ACCESSORIES SET WITHOUT SIDE REINFORCEMENTS

Functions

Components for covering and completing the GS1000 tilt and slide system.

Technical features

Accessories set without side reinforcements consists of:

- flat side protective caps that can be painted as needed
- protective caps for guards
- top and bottom stops
- command striker

To be combined with the GS1000-ML and GS1000-HD 100 versions for sashes weighing up to 100 kg.

Materials

Paintable plastic plugs

Command striker of zamak

Bottom limit stop striker of zamak and rubber

Top limit stop striker of steel and rubber

Stainless steel screws and bolts

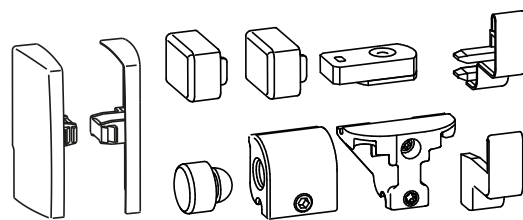

Plugs art. 09774

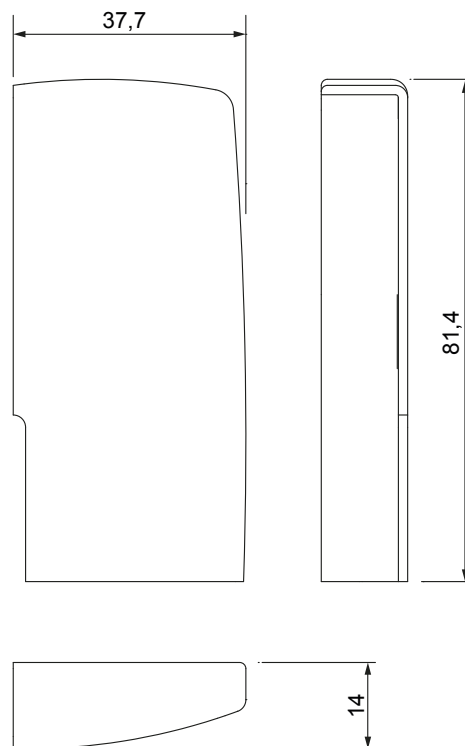

Item code	Description	Range [mm]	PROFILE CROSS - SECTION	GS1000-ML	GS1000-HL	GS1000-HD 100	GS1000-HD 160	GS1000-HD 200	Base Raw	Anodised Elox	Painted	Trend/Gold Brass	Pieces per pack
09774	ACCESSORIES SET WITHOUT SIDE REINFORCEMENTS	-	-	X	-	X	-	-	X		X		1

MOBILE STRIKER

Functions

Component for positioning the mobile sash for GS1000 tilt and slide systems.

Technical features

The mobile striker enables run-by of the sliding sash, for opening the secondary sash.

In configurations with an opening secondary sash, this striker replaces the fixed command striker supplied with the hardware set.

The pin with a spring keeps the striker in position and allows it to move in order to allow opening the secondary sash.

Installation can also be performed with a specific template.

Materials

Zamak striker

Spring and pin of steel

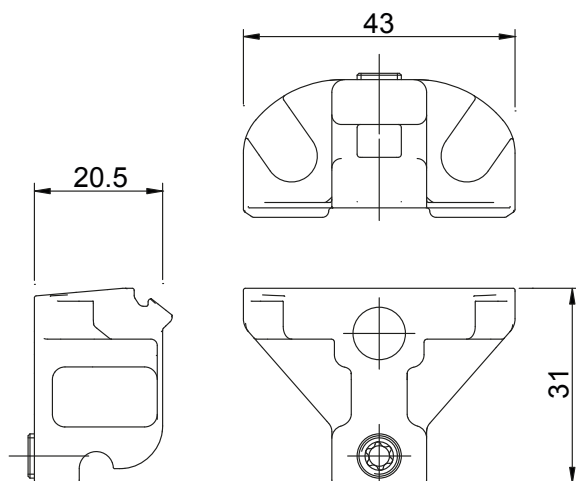
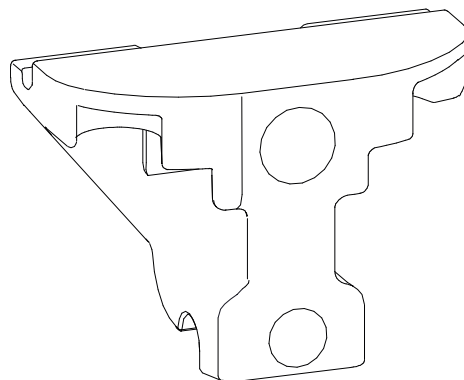

Item code	Description	Range [mm]	PROFILE CROSS - SECTION	GS1000-ML	GS1000-HL	GS1000-HD 100	GS1000-HD 160	GS1000-HD 200	Base Raw	Anodised Elox	Painted	Trend/Gold Brass	Pieces per pack
09790	MOBILE STRIKER	-	-	X	X	X	X	X			X		1

WINDOW HANDLE MECHANISM

Functions

Specific one-way mechanism for GS1000-ML and GS1000-HL tilt and slide versions with window handle.

Technical features

Available in right and left versions, the mechanism must match the specific hardware set for the window handle (art. 09783).

The mechanism can be combined with all the window handles made by GIESSE, both of aluminium and brass (with 7 mm square pin).

The shim supplied, to be positioned inside the profile, between the mechanism and the window handle, enables perfect alignment of the parts.

The mechanism has an incorrect movement safety device integral with the mechanism and fixed pawls, already prepared for any additional locking points.

Materials

Rack, case, incorrect movement safety device slide, cover, mechanism and gear in die-cast zamak

Shims in black polyamide

Screws and spring of zinc-nickel plated steel

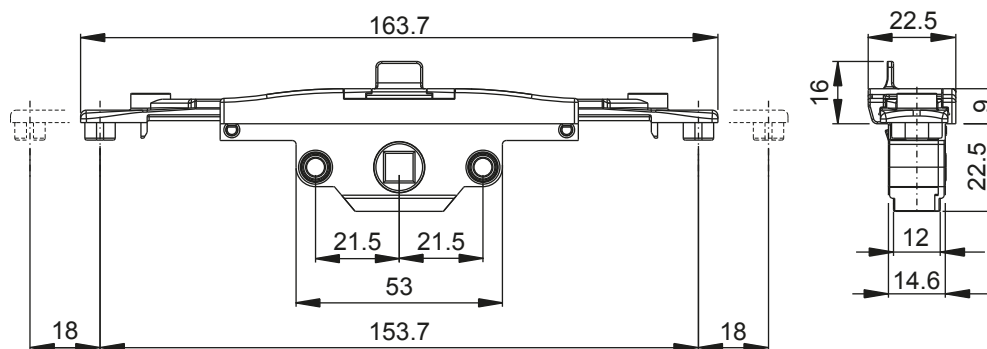
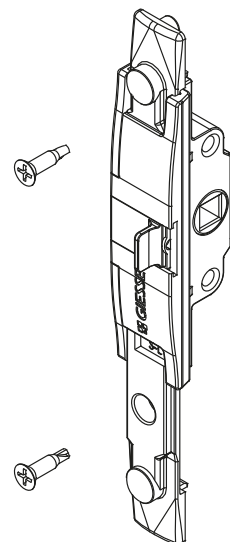

Item code	Description	Range [mm]	PROFILE CROSS - SECTION	GS1000-ML	GS1000-HL	GS1000-HD 100	GS1000-HD 160	GS1000-HD 200	Base Raw	Anodised Elox	Painted	Trend/Gold Brass	Pieces per pack
09751	MECH. LH WINDOW HANDLE GS1000-ML/HL CE	-	-	X	X	-	-	-	X				1
09752	MECH. RH WINDOW HANDLE GS1000-ML/HL CE	-	-	X	X	-	-	-	X				1

GS1000-ML TILT AND SLIDE

KORA WINDOW HANDLE

Functions

Window handle for manually operated GS1000 tilt-and-slide system.

Technical features

Long window handle for manually operated tilt-and-slide system, ML and HL version.

10/7 mm square pin.

Fixing C/C distance 43 mm.

Operation with notches at 0°-90°-180°.

Can be combined with the tilt-and-slide mechanisms.

Materials

Aluminium handle and cover

Zamak case

Rotor made of zinc-plated steel

Trim ring made of acetal resin

Square pin 10/7 mm made of zinc-plated steel

Self-forming screw for fixing to the rotor made of zinc-plated steel

Fixing screws, zinc-coated steel



Overall dimensions

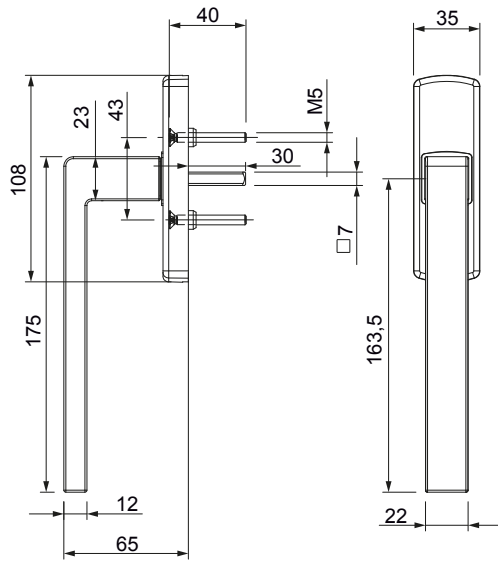

Operating scheme

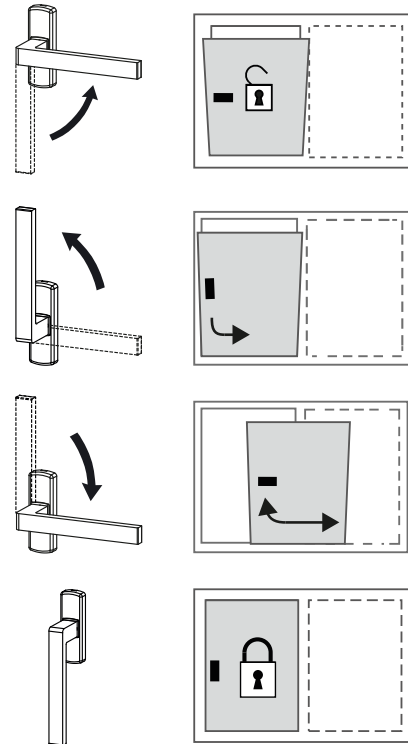

Item code	Description	C/C distance (l)	Handle length (L)	Compatible with mechanisms	GS1000-ML	GS1000-HL	GS1000-HD100	GS1000-HD160	GS1000-HD200	Base Raw	Anodised Elox	Painted	Trend/Gold Brass	Pieces per pack
0246601	WINDOW HANDLE KORA L175 GS1000	43 mm	175 mm	09751-09752-01062	X	X	-	-	-	X	X	X	X	5

PRIMA WINDOW HANDLE

Functions

Window handle for manually operated GS1000 tilt-and-slide system.

Technical features

Long window handle for manually operated tilt-and-slide system, ML and HL version.

10/7 mm square pin.

Fixing C/C distance 43 mm.

Operation with notches at 0°-90°-180°.

Can be combined with the tilt-and-slide mechanisms.

Materials

Aluminium handle and cover

Zamak case

Rotor made of zinc-plated steel

Trim ring made of acetal resin

Square pin 10/7 mm made of zinc-plated steel

Self-forming screw for fixing to the rotor made of zinc-plated steel

Fixing screws, zinc-coated steel

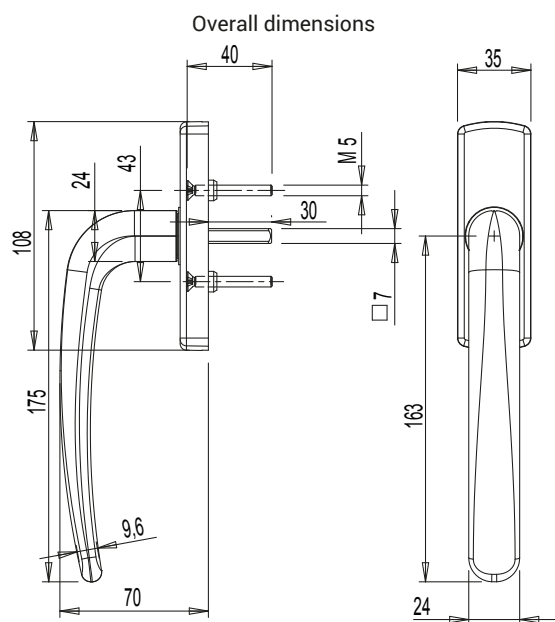

Operating scheme

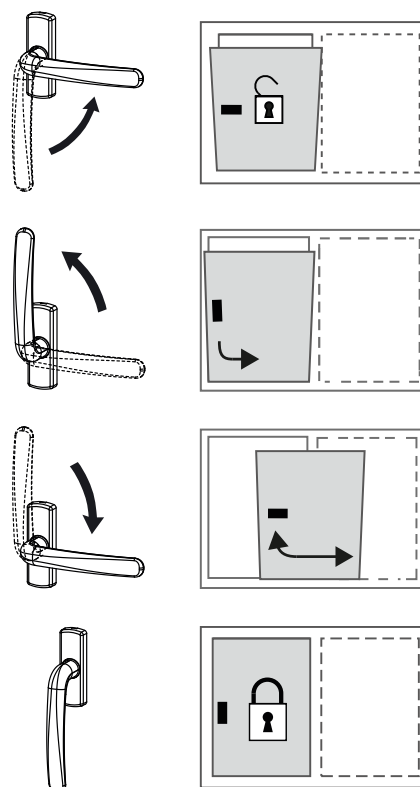

Item code	Description	C/C distance (I)	Handle length (L)	Compatible with mechanisms	GS1000-ML	GS1000-HL	GS1000-HD100	GS1000-HD160	GS1000-HD200	Base Raw	Anodised Elox	Painted	Trend/Gold Brass	Pieces per pack
0243501	PRIMA WINDOW HANDLE L175 GS1000	43 mm	175 mm	09751-09752-01062	X	X	-	-	-	X	X	X	X	5

GS1000-ML TILT AND SLIDE

ASIA WINDOW HANDLE

Functions

Window handle for manually operated GS1000 tilt-and-slide system.

Technical features

Long window handle for manually operated tilt-and-slide system, ML and HL version.

10/7 mm square pin.

Fixing C/C distance 43 mm.

Operation with notches at 0°-90°-180°.

Can be combined with the tilt-and-slide mechanisms.

Materials

Aluminium handle and cover

Zamak case

Rotor made of zinc-plated steel

Trim ring made of acetal resin

Square pin 10/7 mm made of zinc-plated steel

Self-forming screw for fixing to the rotor made of zinc-plated steel

Fixing screws, zinc-coated steel

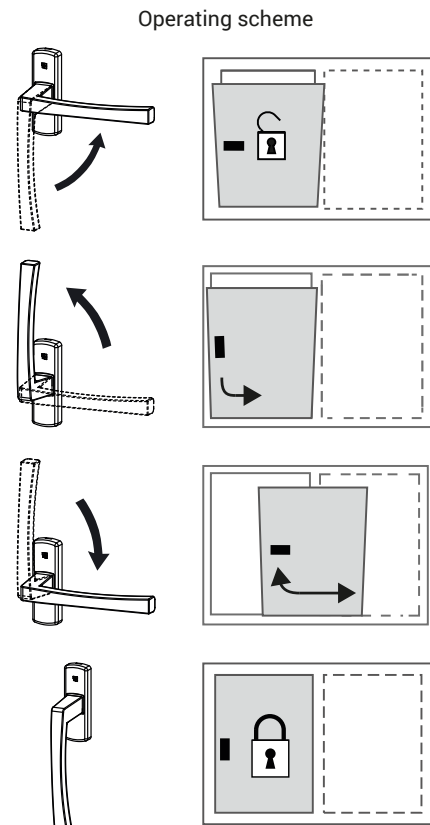
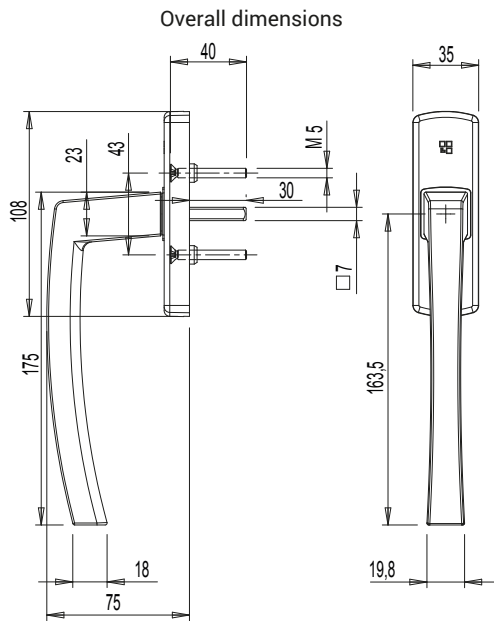

Item code	Description	C/C distance (I)	Handle length (L)	Compatible with mechanisms	GS1000-ML	GS1000-HL	GS1000-HD100	GS1000-HD160	GS1000-HD200	Base Raw	Anodised Elox	Painted	Trend/Gold Brass	Pieces per pack
0244301	ASIA WINDOW HANDLE L175 GS1000	43 mm	175 mm	09751-09752-01062	X	X	-	-	-	X	X	X	X	5